



Atlas Copco



Material removal tools

Material removal tools

CONTENT



High-productivity grinding and cutting off	04
Die grinding.....	16
Sanding and polishing	24
Fine cutting.....	38
Weld flux, rust and paint removal	44
Rough Chiseling.....	48

HIGH-PRODUCTIVITY GRINDING AND CUTTING OFF







Working in a tough environment places high demands on the tools and on the operator. The high power-to-weight ratios of our tools make them comfortable to work with and gives you a superior material removal rate with minimum effort. They are powerful and built to last.

Our tools are available in all sizes and power outputs. Whether it's a small, one-handed angle grinder or a 4.5 kW machine, both offer you superior productivity. Our range of grinders includes both vertical and straight versions to cover all needs in a rough grinding environment.



Die grinding and deburring

- 1 Carbide burrs 
- 2 Mounted points 

Rough grinding and cutting off

- 3 Depressed center wheels 
- 4 Cut off wheels 
- 5 Cup wheels 
- 6 Flap wheels 
- 7 Straight wheels 
- 8 Cone wheels 

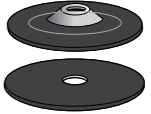
Sanding and polishing

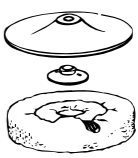
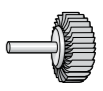
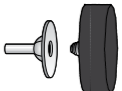
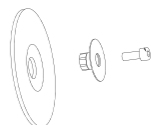
- 9 Fibre discs 
- 10 Wire brushes 
- 11 Polishing bonnets 
- 12 Radial flap wheels 
- 13 Scotch-Brite 
- 14 Fiber discs with backing pad Slimline 

Grinders

for cut-off and depressed center wheels,
Ø 125-230 mm



GTG22



GTG25



GTG40

Extreme productivity grinders are suitable for all rough and heavy grinding tasks.

Our **GTG** models are powered by a motor with the latest turbine technology which gives extremely high power-to-weight ratios compared to normal vane motors. This means that you can select a lighter, more compact tool without sacrificing the material removal rate.

Compared to a vane motor, a turbine motor provides up to 40 percent more efficiency for the same specific job and at the same time reduces the total energy consumption.

LSV grinders have been optimized to get the highest power-to-weight ratio available for conventional vane motors.

They are developed to be durable with low service requirements.



LSV48

Model	Max free speed r/min	Max output kW	Max wheel dia mm	Spindle thread	Spindle length mm	Weight kg	Height over spindle mm	Air consumption at max output l/s	Air consumption at free speed l/s	Rec hose size mm	Air inlet thread BSP	Ordering No.
GTG22-HA G120	12000	2.3	125	-	-	1.9	58	32	8	16	3/8"	8423 2222 10
GTG22-HA G85	8500	2.3	180	-	-	2.1	58	32	8	16	3/8"	8423 2222 20
GTG22-HA G120-M14	12000	2.3	125	M14	20	1.9	78	32	8	16	3/8"	8423 2222 30
GTG25 F120-13	12000	2.5	125	-	-	2.1	61	34	9	16	3/8"	8423 2525 01
GTG25 F120-M14	12000	2.5	125	M14	20	2.1	80	34	9	16	3/8"	8423 2525 10
GTG25 F085-18	8500	2.5	180	-	-	2.2	61	34	9	16	3/8"	8423 2525 02
GTG25 F085-M14	8500	2.5	180	M14	20	2.2	80	34	9	16	3/8"	8423 2525 11
GTG25 F085-13	8500	2.5	125	-	-	2.2	61	34	9	16	3/8"	8423 2525 15
GTG40 F085-18	8500	4.5	180	-	-	3.8	128	60	20	16	1/2"	8423 2900 10
GTG40 F066-23	6600	4.5	230	-	-	4.0	128	60	20	16	1/2"	8423 2910 10
LSV48 SA085-18	8500	1.9	180	M14	9	2.7	88	36	17	16	1/2"	8423 0132 06
LSV48 SA066-23	6600	1.9	230	UNC 5/8"	10	2.9	88	36	17	16	1/2"	8423 0132 08

GTG22 Accessories

Ordering number	Description	Included/Optional	8423 2222 10	8423 2222 20	8423 2222 30
			GTG22-HA G120	GTG22-HA G85	GTG22-HA G120-M14
4080 0048 00	Allen key for flange nut	Included	x	x	
4221 0014 26	Allen key for support handle	Included	x	x	x
4175 0777 90	Flange washer compl. (for grinding applications)	Included	x	x	
4175 0777 92	Flange washer compl. (for cutting-off applications)	Included	x	x	
4080 0862 00	Face spanner	Included			x
4170 1188 90	Locking kit (metric)	Included			x
4175 0643 93	Adapter, backing pad	Included			x
4175 0643 94	Flange nut M14 - type 41 (type 1) cutting wheel (completely flat)	Included			x
4175 0643 96	Flange nut M14 - type 27 (type 42) cutting wheel	Included			x
4170 1888 02	Backing pad compl. Slimline 5" (120mm)	Optional	x		x
4170 1888 05	Backing pad compl. Slimline 7" (180mm)	Optional		x	
4175 0738 90	Whip hose kit (3/8" + RUBAIR16)	Optional	x	x	x
8202 0850 17	Productivity kit	Optional	x	x	x
8202 1350 22	MULTIFLEX-3/8	Optional	x	x	x

Accessories

Accessories Extreme Productivity Grinders	GTG25	GTG40	LSV48
Flange depressed center wheel	4175 0777 90	4175 0194 90	4150 1160 02 (M14)
Flange cut-off wheel	4175 0777 92	4175 0193 90	4150 1160 05 (M14)
Support handle	4175 0705 90	4110 1355 88	4175 0868 82
Backing pad compl. Slimline 5" (125mm)	4170 1888 02*	-	-
Backing pad compl. slimline 7" (180mm)	4170 1888 05	4170 1888 10	-
MultiFlex	8202 1350 22 (3/8" BSP)	8202 1350 60 (1/2" BSP)	8202 1350 60 (1/2" BSP)
Diamond cutting wheels			
Ø 125 mm	3780 5074 61	-	-
Ø 180 mm (valid only for 180mm max wheel Ø)	3780 5074 62	3780 5074 62	3780 5074 62
Spot suction for diamond cutting wheel			
Kit (valid only for 180mm max wheel Ø)	3780 4090 35	-	-
Spot suction kit for depressed center wheel			
Kit Ø 180 mm (valid only for 180mm max wheel Ø)	3780 4090 30	-	-
Add on spot suction			
Ø 125 mm	3780 4032 14	-	-

*Valid only for GTG25 F120-13 (8423 2525 01) and GTG25 F085-13 (8423 2525 15)

For included and/or other optional accessories, check ServAid webpage <https://servaid.atlascopco.com/AssertWeb/en-US/AtlasCopco/Catalogue/1>



Spot suction depressed center wheel



Add on spot suction



Backing pad compl. Slimline 125 mm

Model	Air inlet BSP	Economical air flow	Max hose, 5 m	Coupling	Lubrication	Ordering No.
MIDI-FRL-1/2-BSP EQ10-T13	3/8"	35l/s	Turbo 13	ErgoQic 10	Yes	8202 0850 17
MAXI-F/R-1-BSP C-T16	1/2"	60 l/s	Turbo 16 mm	Claw	No	8202 0850 05
MIDI-FRL-1/2-BSP EQ10-T16	1/2"	40l/s	Turbo 16 mm	ErgoQic 10	Yes	8202 0850 12

Applicable not for all models, check air consumption, turbo grinders do not need lubrication.

Grinders

for cut-off and depressed center wheels,
Ø 80-180 mm



LSV39

These grinders are used for general purpose grinding and cutting off in applications with high demands on productivity and ergonomics.

LSV 19/29/39 grinders are ergonomically designed tools with high power-to-weight ratios. They can be used as one-handed angle grinders. Low vibrations and low noise levels mean that you can work with them all day without strain.

All tools are fitted with a speed governor as standard to ensure optimum process speed at all times. LSV39 models also include a version with an Autobalancer.



LSV19



LSV29

Model	Max free speed r/min	Max output kW	Max wheel diameter mm	Spindle thread	Spindle length mm	Weight kg	Height over spindle mm	Air consumption at max output l/s	Air consumption at free speed l/s	Rec hose size mm	Air inlet thread BSP	Ordering No.
LSV19 S170-08	17000	0.45	80	UNF 3/8"	17	0.7	71	11.2	6.6	10	1/4"	8423 0111 40
LSV29 ST13-100E	13000	0.8	100	3/8-24 UNF	16.6	1.7	71	26	15	10	3/8"	8423 0127 49
LSV29 ST12-100	12000	0.8	100	3/8-24 UNF	17	1.7	75	20	8	10	3/8"	8423 0127 45
LSV29 ST12-115	12000	0.8	115	3/8-24 UNF	17	1.7	75	20	8	10	3/8"	8423 0127 46
LSV29 ST12-125	12000	0.8	125	3/8-24 UNF	17	1.7	75	20	8	10	3/8"	8423 0127 47
LSV39 SA12-125	12000	1.8	125	M14	21	1.8	94	29.8	17.6	13	3/8"	8423 0133 01
LSV39 SA085-125	8500	1.8	125	M14	21	1.8	94	29.8	17.6	13	3/8"	8423 0133 09
For diamond cutting												
LSV39 SA085-180	8500	1.8	180	M14	21	1.8	94	61.1	16.3	13	3/8"	8423 0133 12

SA = Autobalancer

Accessories

Accessories Grinders	LSV19	LSV29	LSV39	LSV53	See illustration
Flange nut	-	-	4150 1160 02	4170 0758 01	-
Flange nut kit	4150 1158 80	4150 1160 80	-	-	-
Support handle	-	4175 0868 80	4175 0868 80	-	-
Vibration damped handle	-	4150 1521 80	4150 1521 80	-	-
Diamond cutting wheels					
Ø 100 mm	-	3780 5074 00	-	-	-
Ø 125 mm	-	-	3780 5074 61	-	-
Spot suction kit for depressed center wheel					
Ø 125 mm wheel kit	-	3780 4008 70	3780 4008 73*	-	1
Nut 5/8" (incl. in kit)	-	3780 2722 00	-	-	-
Add on spot suction					
Ø 115-150 mm	-	3780 4032 14	3780 4032 14	-	-
Alu-cut guard cover kit					
Saw blade, Ø 125 mm for cutting applications, 30 teeth, 2 mm thick	-	-	4112 1164 00	-	-
Saw blade, Ø 125 mm for milling applications, 6 teeth, 4 mm thick	-	-	4112 1162 00	-	-
MultiFlex	8202 1350 20	8202 1350 22	8202 1350 22	-	-

*Valid only for LSV39 SA12-125 (8423 0133 01)

For included and/or other optional accessories, check ServAid webpage <https://servaid.atlascopco.com/AssertWeb/en-US/AtlasCopco/Catalogue/1>

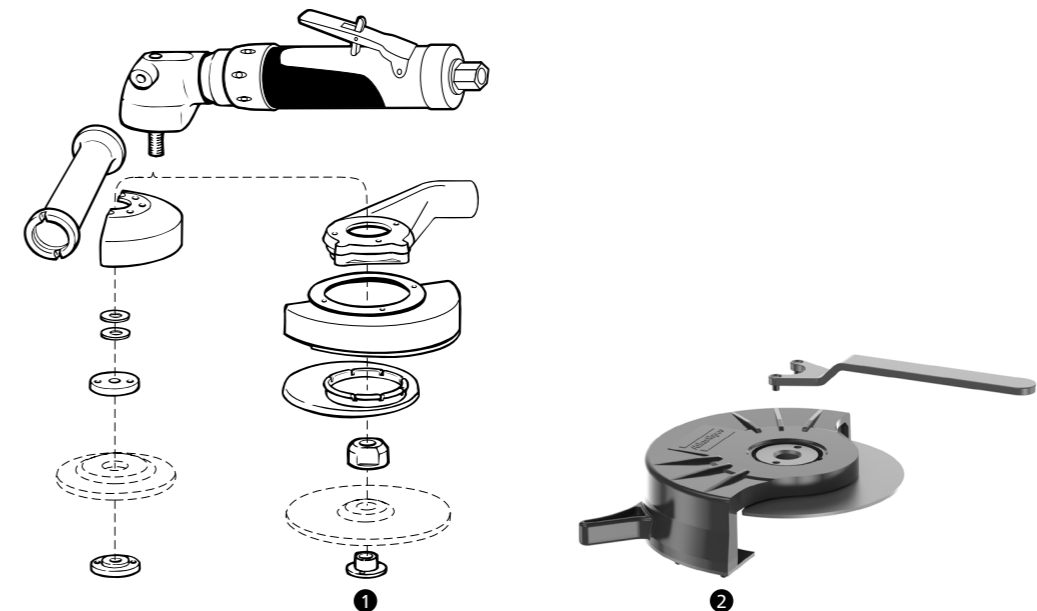

Productivity Kits

Model	Air inlet BSP	Economical air flow	Max hose, 5 m	Coupling	Lubrication	Ordering No.
MIDI-FRL-1/2-BSP EQ08-C10	1/4"	16l/s	Cablair 10	ErgoQic 08	Yes	8202 0850 03
MIDI-FRL-1/2-BSP EQ10-T13	3/8"	35l/s	Turbo 13	ErgoQic 10	Yes	8202 0850 17

Grinders

for cup wheels & wire brushes

For rough grinding on open surfaces with cup wheels or wire brushes. Applications of this type call for tools with high power outputs.

GTG40 is powered by a turbine motor, which gives an extremely high power-to-weight ratio compared to a vane motor. In addition, the efficiency of a turbine motor is much higher and reduces energy consumption for the same specific job by up to 40% compared to a conventional vane grinder.



GTG40

Model	Max free speed r/min	Max output kW	Max cup wheel diameter mm	Max brush diameter mm	Spindle thread	Spindle length mm	Weight kg	Height over spindle mm	Air consumption at max output l/s	Air consumption at free speed l/s	Rec hose size mm	Air inlet thread BSP	Ordering No.
GTG40 S060	6000	4.5	-	140	UNC 5/8"	23	3.6	132	60	20	16	1/2"	8423 2930 00
GTG40 S060-C15	6000	4.5	150	-	UNC 5/8"	16	4.3	126	60	20	16	1/2"	8423 2930 10

Accessories

Accessories Grinders	GTG40	See illustration
Support handle	4110 1355 88	1
Vibration damped handle	4150 1521 80	-
Attachment set for cup wheel with plane hole	4175 0178 90	-
Wheel friction plate	4175 0186 90	-
MultiFlex	8202 1350 60	

For included and/or other optional accessories, check ServAid webpage <https://servaid.atlascopco.com/AssertWeb/en-US/AtlasCopco/Catalogue/1>



Productivity Kits

Model	Air inlet BSP	Economical air flow	Max hose, 5 m	Coupling	Lubrication	Ordering No.
MAXI-F/R-1-BSP C-T16	1/2"	60 l/s	Turbo 16 mm	Claw	No	8202 0850 05

Straight grinders

for straight wheels

Straight grinders are normally used when grinding inside larger cavities on open surfaces.

LSR 48/64 tools are durable and ideal for tougher applications. The LSR 48 has an Autobalancer as standard to minimize vibrations.



LSR48



LSR64

Model	Max free speed r/min	Max output kW	Max wheel dia mm	Max brush dia mm	Length mm	Weight kg	Spindle thread	Spindle length mm	Air consumption at max output l/s	Air consumption at free speed l/s	Rec hose size mm	Air inlet thread BSP	Auto balancer	Ordering No.
LSR48 S090-10	9000	1.5	100	-	495	3.2	UNC 1/2"	37	28.0	11.0	16	1/2"	●	8423 1430 02
LSR48 S120-10	12000	1.8	100	-	495	3.5	UNC 5/8"	49	30.0	13.0	16	1/2"	●	8423 1430 09
LSR48 S120-13	12000	1.8	125	-	487	3.6	UNC 5/8"	42	30.0	13.0	16	1/2"	●	8423 1430 06
LSR64 S060-15	6000	2.3	150	-	535	5.4	UNC 5/8"	55	41.0	11.0	16	1/2"	-	8423 1640 22
LSR64 S072-13	7200	2.5	125	-	535	5.4	UNC 5/8"	55	45.0	14.0	16	1/2"	-	8423 1640 30
LSR64 S100-15	10000	2.9	150	-	535	5.8	UNC 5/8"	55	53.0	26.0	16	1/2"	-	8423 1640 55
For wire brushes														
LSR64 S041	4100	1.6	-	140	535	5.4	UNC 5/8"	55	29.0	7.0	16	1/2"	-	8423 1640 14

Accessories

Accessories Straight Grinders	LSR 48 UNC 1/2"	LSR 48 UNC 5/8"	LSR 64	See illustration
Flange nut	4150 0776 00	4150 0670 00	4150 0670 00	2
Front washer	4150 0731 00	4150 0671 00	4150 0671 00	3
Rear flange for 0-25x16 mm wheel (WxH)	4150 0732 01	-	-	1
Rear flange for 25x16 mm wheel (WxH)	4150 0732 02	-	-	1
Rear flange for 25x25 mm wheel (WxH)	4150 0732 04	-	-	1
Rear flange for 20-25x16 mm wheel (WxH)	-	4150 0619 00	4150 0619 00	1
Rear flange for 20-25x20 mm wheel (WxH)	-	4150 1650 00	4150 1650 00	1
Rear flange for 20-25x25 mm wheel (WxH)	-	4150 0713 00	4150 0713 00	1
Steel wire brush Ø115 mm for 5/8" spindle	-	-	4170 0491 00	
MultiFlex	8202 1350 60	8202 1350 60	8202 1350 60	

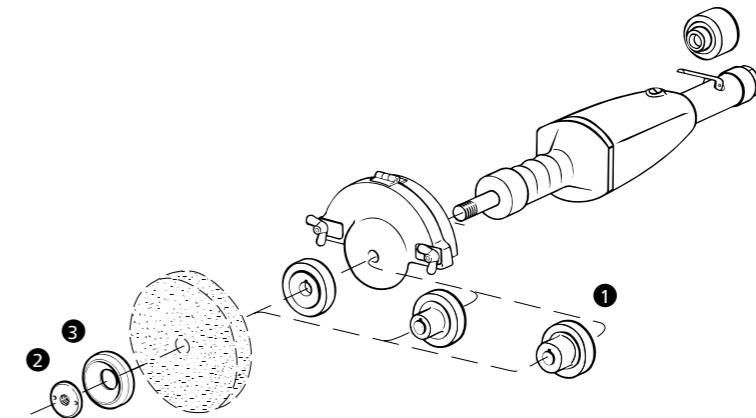

Productivity Kits

Model	Air inlet BSP	Economical air flow	Max hose, 5 m	Coupling	Lubrication	Ordering No.
MIDI-FRL-1/2-BSP EQ10-T16	1/2"	40 l/s	Turbo 16 mm	ErgoQic 10	Yes	8202 0850 12*

Applicable not for all models, check air consumption

Straight grinders

for cone wheels



LSR48 CW

Straight grinders with cone wheels or collets are suitable for grinding or smoothing of edges, welds, holes and cavities.

LSR 48 tools are durable and ideal for tougher applications. The LSR 48 has an Autobalancer as standard to minimize vibrations.

Model	Max free speed r/min	Max output kW	Length mm	Weight kg	Air consumption at max output l/s	Air consumption at free speed l/s	Rec hose size mm	Air inlet thread BSP	Auto balancer	Scatter damped	Ordering No.
LSR48 S090-CW	9000	1.5	450	2.3	28	11	16	1/2"	●	-	8423 1430 03
LSR48 S120-CW	12000	1.8	450	2.3	30	13	16	1/2"	●	-	8423 1430 05
LSR48 S150-CW	15000	2.0	450	2.3	35	19	16	1/2"	●	-	8423 1430 08

Accessories

Model	LSR48	See illustration
Adapter for cone with thread		
UNC/W 5/8"	4150 0945 01*	2
Collet type		
Nut	4150 0849 00	1a
Collet Ø 6 mm	4150 1453 00	1b
Collet Ø 8 mm	4150 0706 00	1b
Collet Ø 9 mm	4150 0765 00	1b
Collet holder	4150 0680 01	1c
MultiFlex	8202 1350 60	

NOTE: Adapters are not included with the tool, and need to be ordered to attach a cone wheel.

*LSR48 has UNC 1/2" spindle for direct attachment of a cone wheel. For UNC 5/8" spindle or collet use an adapter (not included).

For included and/or other optional accessories, check ServAid webpage <https://servaid.atlascopco.com/AssertWeb/en-US/AtlasCopco/Catalogue/1>

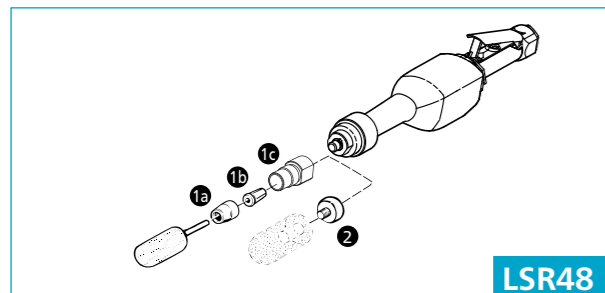

LSR48

Productivity Kits

Model	Air inlet BSP	Max air flow	Max hose, 5 m	Coupling	Lubrication	Ordering No.
MIDI-FRL-1/2-BSP EQ10-T16	1/2"	40 l/s	Turbo 16 mm	ErgoQic 10	Yes	8202 0850 12



DIE GRINDING



Atlas Copco die grinders are available in straight or angle versions in a wide range of sizes and power outputs. All the tools fulfil the highest standards and requirements in terms of ergonomics, accessibility and productivity. Like all Atlas Copco tools, they are easy to work with and built to last.

Die grinders

up to 0.5 kW



LSF19

Die grinders are an excellent choice for high quality finishing and surface preparation in applications where accessibility is your first priority.

Atlas Copco die grinders are high quality tools with compact, ergonomic designs that offer excellent accessibility.

LSF12/19 are straight models, ergonomically designed for operator comfort and equipped with a speed governor for optimum process speed. LSF 19 models are available in scatter damping versions, which give improved life length of burrs and reduce vibrations for the operator.

LSV12/19 are angle versions with the same features as the straight models.

LSF07 is a high-speed pencil-type tool for precision grinding and polishing.



LSV12



LSV19



LSF07



LSF12

Model	Max free speed r/min	Max output kW	Collet size mm	Length mm	Weight kg	Air consumption at max output l/s	Air consumption at free speed l/s	Rec hose size mm	Air inlet thread BSP	Scatter damped	Ordering No.
Straight die grinders											
LSF12 S200-1	20000	0.24	6	170	0.36	8.1	2.6	8	1/4"	-	8423 1124 01
LSF12 S250-1	25000	0.29	6	170	0.36	8.5	3.4	8	1/4"	-	8423 1124 02
LSF12 S310-1	31000	0.32	6	170	0.36	9.2	4.2	8	1/4"	-	8423 1124 03
LSF12 S400-1	40000	0.36	6	170	0.36	9.8	7.0	8	1/4"	-	8423 1124 04
LSF19 S200-1	20000	0.5	6	193	0.5	9.6	3.5	10	1/4"	●	8423 1224 80
LSF17 S300-1	30000	0.28	6	170	0.4	19	6		1/4"	●	8423 1224 19
LSF19 S300-1	30000	0.5	6	193	0.5	11.3	6.6	10	1/4"	●	8423 1224 81
LSF19 S300-1/R	30000	0.5	6	193	0.5	11.3	6.6	10	1/4"	-	8423 1224 89
LSF19 S460-1	46000	0.5	6	193	0.5	11.4	15	10	1/4"	●	8423 1224 82
Straight extended die grinders											
LSF19 S200E-1	20000	0.5	6	293	0.7	9.6	3.5	10	1/4"	●	8423 1224 85
LSF19 S300E-1	30000	0.5	6	293	0.7	11.3	6.6	10	1/4"	●	8423 1224 86
LSF19 S300E-1/R	30000	0.5	6	293	0.7	11.3	6.6	10	1/4"	-	8423 1224 88
LSF19 S460E-1	46000	0.5	6	293	0.7	11.4	15	10	1/4"	●	8423 1224 87
LSF19 S460E-1/R	46000	0.5	6	293	0.7	11.4	15	10	1/4"	-	8423 1224 90
Angle die grinders											
LSV12 S200-1	20000	0.29	6	166	0.54	9.5	6.4	8	1/4"	-	8423 1124 06
LSF17 S300-1	30000	0.28	6	170	0.4	19	6		1/4"	●	8423 1224 19
High speed pen											
LSF07 S850	88000	0.10	3	173	0.4	2.2	2.3	4.5	-	-	8423 1222 03

R=Rigid models

Accessories

Model	LSF07	LSF/LSV12	LSF/LSV19	See illustration
Collets				
Collet Ø 1/8"	4150 1822 00	4150 2226 46	4150 0082 00	1
Collet Ø 1/4"	-	4150 2226 03	4150 0076 00	1
Collet Ø 3/16"	-	-	4150 0649 00	1
Collet Ø 5/32"	-	-	4150 0648 00	1
Collet Ø 5/16"	-	-	4150 0074 00	1
Collet Ø 3 mm	4150 1800 00	4150 2226 46	4150 0081 00	1
Collet Ø 5 mm	-	-	4150 0075 01	1
Collet Ø 6 mm	-	4150 2226 03	4150 0075 00	1
Collet Ø 8 mm	-	-	4150 0074 00	1
Collar	-	4150 2226 02	-	7
Collet nut	-	4150 2226 04	4150 0760 00	3
Collet holder	-	4150 2226 21	4150 1262 00	-
Extension 75 mm (3"). Only for rigid (-R) models	-	-	4150 0674 00	4
For machining of plastic and fibreglass*				
Spot suction kit burr (diamond burr not included)	-	-	3780 3015 22*	6
Spot suction kit drum (diamond drum not incl). For use with 6 mm collet	-	-	3780 4011 61*	6
Diamond drum Ø 27 mm	-	-	3780 5033 00	5
Diamond cylinder kit Ø 27mm	-	-	3780 5033 01	5
Shaft Ø 6 mm (included in spot suction kit)	-	-	3780 5090 30	-
Locking screw for drum (included in spot suction kit)	-	-	3780 5090 60	-
MultiFlex	-	8202 1350 20	8202 1350 20	

*For LSF models only.

For included and/or other optional accessories, check ServAid webpage <https://servaid.atlascopco.com/AssertWeb/en-US/AtlasCopco/Catalogue/1>

Only for LSF/LSV12

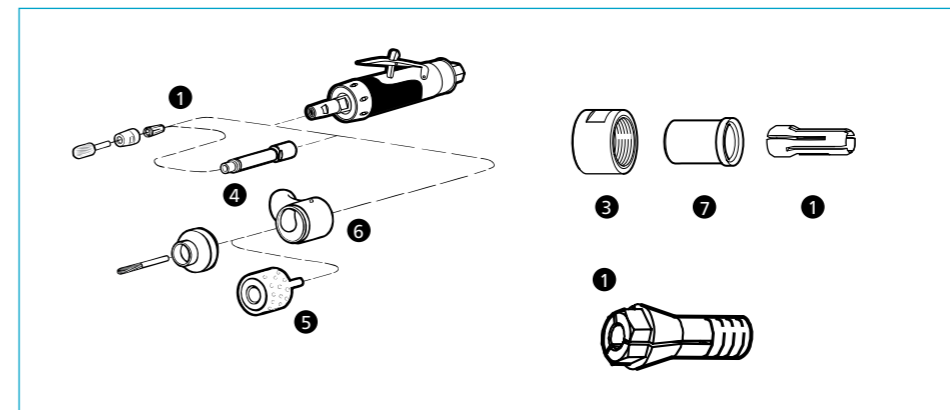

Model	Air inlet BSP	Economical air flow	Max hose, 5 m	Coupling	Lubrication	Ordering No.
MIDI-FRL-1/2-BSP EQ08-C10	1/4"	16l/s	Cablair 10	ErgoQic 08	Yes	8202 0850 03

Die grinders

from 0.7kW to 1.8kW



LSF39

In applications where you want more power but still need accessibility, these die grinders will be your first choice.

LSF 29/39 die grinders are designed with focus on power and productivity. The tools are equipped with a speed governor for optimum process speed. They are available in scatter damping versions, which give improved life length of burrs and reduced vibrations for the operator.



LSF29



LSF29

Model	Max free speed r/min	Max output kW	Collet size mm	Length mm	Weight kg	Air consumption at max output l/s	Air consumption at free speed l/s	Rec hose size mm	Air inlet thread BSP	Scatter damped	Ordering No.
Straight extended die grinders											
LSF29 S250E	25000	1	6	332	1.4	22	9	13	3/8	-	8423 0127 14
LSF29 S250E-HD	25000	1	6	332	1.6	22	9	13	3/8	-	8423 0127 26
LSF29 S180E	18000	0.9	6	332	1.4	20	6	13	3/8	•	8423 0127 08
LSF29 S180E-HD	18000	0.9	6	332	1.6	20	6	13	3/8	•	8423 0127 24
LSF29 S150E	15000	0.8	6	332	1.4	18	4	13	3/8	•	8423 0127 04
LSF29 S120E-HD	12000	0.7	6	332	1.6	17	4	13	3/8	-	8423 0127 22
LSF29 S030	3000	0.8	6	257	1.2	20	6	13	3/8	-	8423 0127 18
LSF29 S070	7000	1	6	256	1.2	22	9	13	3/8	-	8423 0127 20
Straight die grinders											
LSF29 S250	25000	1	6	213	0.8	22	9	13	3/8	-	8423 0127 11
LSF29 S250-HD	25000	1	6	213	1.2	22	9	13	3/8	-	8423 0127 27
LSF29 S180	18000	0.9	6	213	0.8	20	6	13	3/8	•	8423 0127 05
LSF29 S180-HD	18000	0.9	6	213	1.2	20	6	13	3/8	•	8423 0127 25
LSF29 S150	15000	0.8	6	213	0.8	20	9.3	13	3/8	-	8423 0127 02
LSF29 S120	12000	0.7	6	213	0.8	20	7.4	13	3/8	-	8423 0127 00
LSF29 S120-HD	12000	0.7	6	213	1.2	20	7.4	13	3/8	•	8423 0127 23
LSF29 S030E	3000	0.8	6	381	1.8	20	6	13	3/8	•	8423 0127 19
LSF29 S070E	7000	1	6	381	1.8	22	9	13	3/8	•	8423 0127 21
LSF39 S120E	12000	1.5	6	367	1.6	24	9	13	3/8	-	8423 1233 00
LSF39 S150E	15000	1.7	6	367	1.6	28	12	13	3/8	-	8423 1233 01
LSF39 S180E	18000	1.8	6	367	1.6	31	15	13	3/8	-	8423 1233 02
LSF39 S250E	25000	1.8	6	367	1.6	33	33	13	3/8	-	8423 1233 03
Angle die grinders											
LSV29 S150	15000	0.7	6	251	1.2	21	8	13	3/8	-	8423 0127 40

Accessories

Model	LSF 29	LSF39	See illustration
Collets			
Collet Ø 1/4"	4150 0076 00	-	1
Collet Ø 3/16"	4150 0649 00	-	
Collet Ø 5/16"	4150 0074 00	-	
Collet Ø 3 mm	4150 0081 00	-	1
Collet Ø 5 mm	4150 0075 01	-	
Collet Ø 6 mm	4150 0075 00	4150 1453 00	1
Collet Ø 8 mm	4150 0074 00	4150 0706 00	1
Collet Ø 9 mm	-	4150 0765 00	1
Collet Ø 10 mm	-	4150 0681 00	1
Collet nut	4150 0760 00	4150 0849 00	3
Collet holder (LSF)	-	4150 1587 00	-
Collet holder and collet nut (LSF)	4110 0844 90	-	-
Extension 75 mm (3")	4150 0674 00	-	4
For machining of plastic and fiberglass*			
Cone wheel adapter UNC/W 5/8	-	4150 2292 90	
Cone wheel adapter UNF3/8	4150 2326 85	-	7
Spot suction kit drum (diamond drum not incl.) For use with 8 mm collet	-	-	6
Diamond drum Ø 52 mm	3780 5035 00	-	5
Diamond cylinder kit Ø 52mm	3780 5035 01	-	5
Locking nut (included in spot suction kit)	3780 5092 00	-	-
MultiFlex	8202 1350 22	8202 1350 22	-
Extension 700mm*	8423 0127 70	-	2

* Valid only for LSF29 S150E (8423 0127 04), LSF29 S180E (8423 0127 08), LSF29 S250E (8423 0127 14)
For included and/or other optional accessories, check ServAid webpage <https://servaid.atlascopco.com/AssertWeb/en-US/AtlasCopco/Catalogue/1>

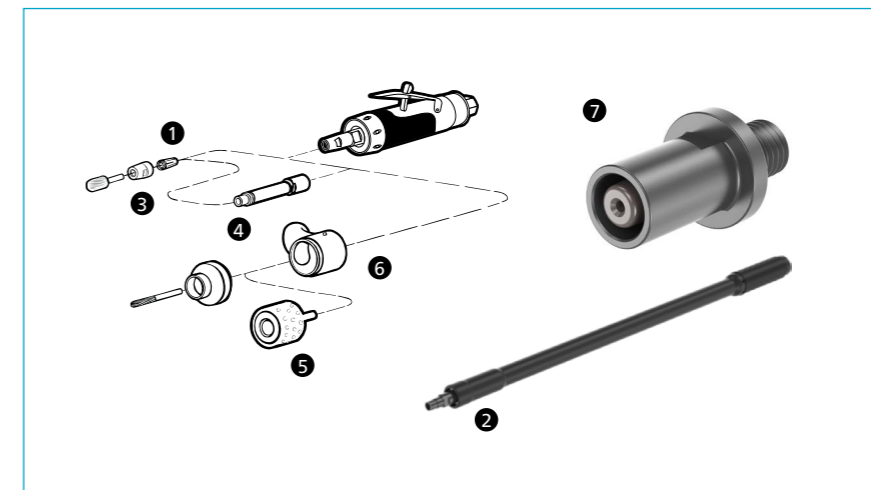

Productivity Kits

Model	Air inlet BSP	Economical air flow	Max hose, 5 m	Coupling	Lubrication	Ordering No.
MIDI-FRL-1/2-BSP EQ10-T13	3/8"	35l/s	Turbo 13	ErgoQic 10	Yes	8202 0850 17

Beveling tools

Cutting Edge Technology

Beveling gives you a sound welded joint with a good amount of weld in place for maximum strength. And it is safer, more resistant and easier on the eye. Rounded edges of metal surfaces gives you proper thickness of coatings to avoid corrosion due to moisture, air, dust and even chipping. The LSB39 is an excellent combination of power, design, durability and ergonomics for chamfering, deburring and giving radius edges to metal plates in stainless steel, mild steel and aluminium.



LSB39

Model	Max free speed r/min	Max bevel width mm	Max radius mm	Max. power kW	weight kg	Max height over guide plate mm	Air consumption max output l/s	Air consumption free speed l/s	Rec. hose size mm	Air inlet thread BSP	Ordering No.
LSB39 S085	8500	8	4	1.8	2.6	111	29.5	16.3	13	3/8"	8423 0133 10

Beveling Matrix

	Radius 2 mm	Radius 3 mm	Radius 4 mm	Chamfer 30°	Chamfer 35°	Chamfer 45°	Chamfer 55°	Chamfer 60°
LSB39								
Milling Head	4150224090	4150224090	4150224090	4150224094	4150224098	4150224090	4150224096	4150224104
Guide bearing	4150224080	4150224091	4150224092	4150224095	4150224099	4150224093	4150224097	4150224105
Insert	4150224193	4150224190	4150224191	4150224192	4150224192	4150224192	4150224192	4150224192

NOTE: Each type of inserts work with respective Guide bearing only
For included and/or other optional accessories, check ServAid webpage <https://servaid.atlascopco.com/AssertWeb/en-US/AtlasCopco/Catalogue/1>

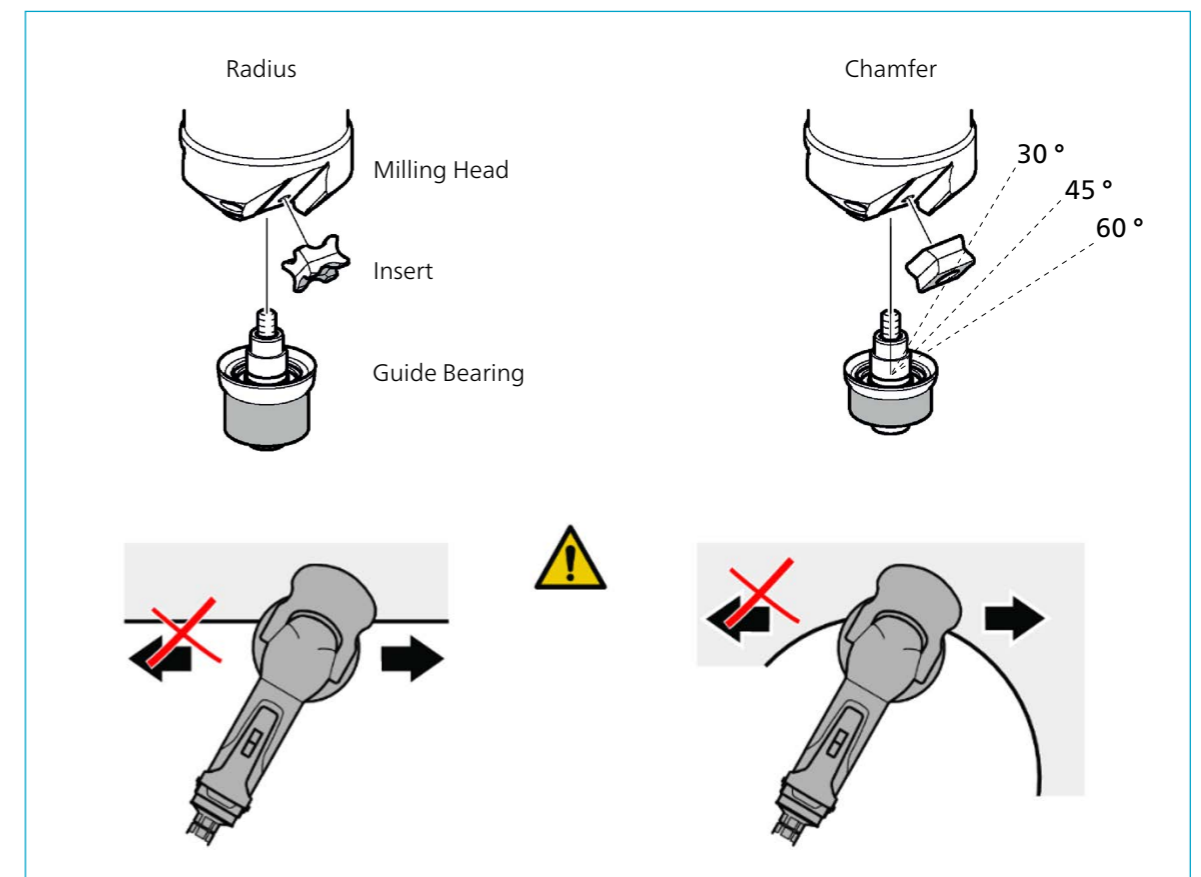

LSB39 S085

Technical specifications:

Mills contours and cutouts in carbon steel, stainless steel, and aluminum.

Adjustable depth control

3 indexable carbide inserts for beveling are included

Standard 45° milling head is included

Bevel width: up to 8 mm

Milling radius: up to 4 mm

Power: 1.8 KW

Spindle speed: 8500 RPM

Weight: 5.7 lbs (2.6 kg)

SANDING AND POLISHING



Atlas Copco handheld sanders are available in a range of different versions for all type of jobs. From extreme productivity sanding to fine grit sanding for the finest possible surface finish.

Our sanders are suitable for use with all types of abrasives, from dry sanding to wet sanding, from paper to wire brushes, and polishing with velcro pads or lambswool. We also offer belt sanders in our range. Our tools have user-friendly ergonomic designs with high power-to-weight ratios, an autobalancer that reduces vibrations, and good accessibility to the workpiece.

The range includes sanders equipped with dust extraction to lower the operator's exposure to dust.

Sanders

Extreme productivity
for fiber discs, Ø 180-230 mm



GTG22



GTG25



LSV48

Atlas Copco extreme productivity sanders are durable with all-aluminum housings that make them suitable for the toughest working environments.

GTG sanders are powered by turbine technology which gives extremely short process times due to high power-to-weight ratios.

LSV48 is our most powerful angle vane sander with 1.9 kW of power for extreme productivity.

All the tools have a speed governor to ensure optimum process speed and an Autobalancer to reduce vibrations.



GTG40

Model	Max free speed r/min	Max output kW	Max pad dia mm	Spindle thread	Spindle length mm	Weight kg	Height over spindle mm	Air consumption at max output l/s	Air consumption at free speed l/s	Rec hose size mm	Air inlet thread BSP	Ordering No.
GTG22-HA S85-5/8	8500	2.3	180	UNC 5/8"	23	1.7	81	32	8	16	3/8"	8423 2222 40
GTG22-HA S085-M14	8500	2.3	180	M14	23	1.7	81	32	8	16	3/8"	8423 2222 50
GTG25-S085	8500	2.5	180	UNC 5/8"	23	2.0	84	34	9	16	3/8"	8423 2525 03
GTG25-S085-M14	8500	2.5	180	M14	23	2.0	84	34	9	16	3/8"	8423 2525 04
GTG40 S060	6000	4.5	230	UNC 5/8"	23	3.6	132	60	20	16	1/2"	8423 2930 00
LSV48 SA066	6600	1.9	180	UNC 5/8"	21	2.3	78	36	17	16	1/2"	8423 0132 00
LSV48 SA085	8500	1.9	180	UNC 5/8"	21	2.3	78	36	17	16	1/2"	8423 0132 02
LSV48 SA085-M14	8500	1.9	180	M14	18	2.3	78	36	17	16	1/2"	8423 0132 03

Backing pad not included

GTG22 Accessories

Ordering number	Description	Included/Optional	8423 2222 40	8423 2222 50
			GTG22-HA S85-5/8	GTG22-HA S85-M14
4221 0014 26	Allen key for support handle	Included	x	x
4080 0201 00	Face spanner	Included	x	x
4170 1188 91	Locking kit (imperial)	Included	x	
4170 1188 90	Locking kit (metric)	Included		x
4170 1192 90	Pad (backing pad, UNC 5/8" thread)	Optional	x	
4170 1192 91	Pad (Spiralcool backing pad, M14 thread)	Optional		x
4175 0738 90	Whip hose kit (3/8" + RUBAIR16)	Optional	x	x
3780 4090 27	Dust extraction kit	Optional	x	x
8202 0850 17	Productivity kit	Optional	x	x
8202 1350 22	MULTIFLEX-3/8	Optional	x	x

Accessories

Model	GTG 25	GTG40	LSV48	See illustration
Backing set, standard type				
Ø 125mm - 5/8" - soft	-	-	4170 0768 80	-
Ø 180mm - 5/8" - soft	-	-	4170 0756 80	-
Ø 180mm - 5/8" - stiff	-	-	4170 0757 80	-
Backing set with cooling ribs				
Ø 125mm - 5/8" and M14, medium	-	-	4150 1962 80	-
Ø 180 mm - 5/8" and M14, stiff	4150 1962 83	4150 1962 83	4150 1962 83	-
Ø 180 mm - 5/8" and M14, medium	4150 1962 81	4150 1962 81	4150 1962 81	-
Backing set, heavy duty type				
Ø 120 mm - M14	-	-	4175 0883 93	-
Ø 162 mm - M14	-	-	4175 0883 91	-
Pad (Spiralcool backing pad, M14 thread)	4170 1192 91	4170 1192 91	4170 1192 91	-
Ø 120 mm - 5/8"	-	-	4175 0883 92	-
Ø 162 mm - 5/8"	-	-	4175 0883 90	-
Pad (backing pad, UNC 5/8" thread)	4170 1192 90	4170 1192 90	4170 1192 90	-
Flange washers				
Flange washer for 5/8"	-	-	4175 0893 00	5
Flange washer for M14	-	-	4175 0893 01	5
Wheel friction plate				
Wheel friction plate	-	4175 0186 90	-	-
Hand shield				
Hand shield	-	4175 0165 90	-	-
Support handle				
Support handle	4175 0705 90	4110 1355 88	4175 0868 80	-
Vibration damped handle	4150 1521 80	4150 1521 80	4150 1521 80	-
Positioner for support handle				
Positioner for support handle	-	4175 0164 90	-	-
Spot suction kit for sanding with fibre disc				
Ø 180 mm dust extraction kit	3780 4090 27	-	3780 4093 40	-
Suction cap Ø 180 mm with brush (incl. in kit)	3780 2675 00	3780 2675 00	3780 2675 00	2
Backing pad Ø 180 mm (incl. in kit)	3780 2710 60	3780 2710 60	3780 2710 60	3
Distance washer 12 mm (incl. in kit)	3780 2721 40	3780 2721 40	3780 2721 50	6
Nut 5/8" (incl. in kit)	3780 2722 00	3780 2722 00	3780 2726 70	5
Brush for suction cap, 30 mm Ø 180 mm				
Brush for suction cap, 30 mm Ø 180 mm	3780 2677 30	3780 2677 30	3780 2677 30	-
MultiFlex				
MultiFlex	8202 1350 22	8202 1350 60	8202 1350 24	7

For included and/or other optional accessories, check ServAid webpage <https://servaid.atlascopco.com/AssertWeb/en-US/AtlasCopco/Catalogue/1>

Productivity Kits

Model	Air inlet BSP	Economical air flow	Hose, 5 m	Coupling	Lubrication	Ordering No.
MIDI-FRL-1/2-BSP EQ10-T13	3/8"	35l/s	Turbo 13	ErgoQic 10	Yes	8202 0850 17
MAXI-F/R-1-BSP C-T16	1/2"	60 l/s	Turbo 16 mm	Claw	No	8202 0850 05
MIDI-FRL-1/2-BSP EQ10-T16	1/2"	40l/s	Turbo 16 mm	ErgoQic 10	Yes	8202 0850 12

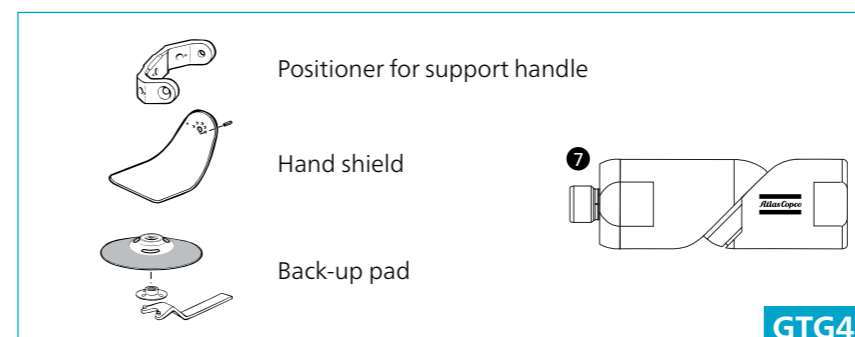

GTG40

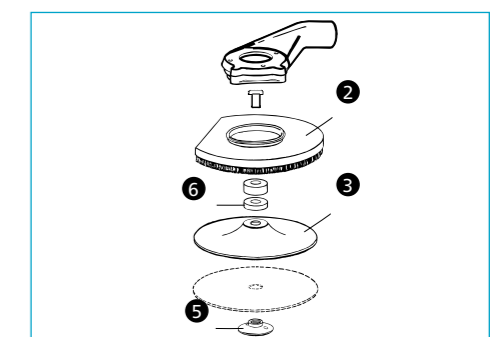

Sanders

dust extraction
for fiber discs, Ø 125-180 mm



LSV39



LSV29

LSV29 tools are small yet powerful, one-handed sanders. They are available in various speeds and also in a wet sanding version.

LSV39 has an incredibly 1.8 kW in a very small package, making this the most versatile tool we have! No matter if you are doing rough grinding or work in cramped spaces, this will be the tool for you.

Model	Max free speed r/min	Max output kW	Max pad dia mm	Spindle thread	Spindle length mm	Weight kg	Height over spindle mm	Air consumption at max output l/s	Air consumption at free speed l/s	Rec hose size mm	Air inlet thread BSP	Ordering No.
LSV29 S060-5/8	6000	0.8	180	5/8-11 UNC	32	1.5	86	20	7	13	3/8"	8423 0127 37
LSV29 S060-M14	6000	0.8	180	M14	23	1.5	86	20	7	13	3/8"	8423 0127 50
LSV29 S040-5/8	4000	0.7	180	5/8-11 UNC	32	1.5	86	19	6	13	3/8"	8423 0127 35
LSV39 S066-5/8	6600	1.65	180	UNC 5/8"	28	1.6	96	26.2	11.6	13	3/8"	8423 0133 05
LSV39 S066-M14	6600	1.65	180	M14	28	1.6	96	26.2	11.6	13	3/8"	8423 0133 06
LSV39 S085-5/8	8500	1.80	180	UNC 5/8"	28	1.6	96	29.5	16.3	13	3/8"	8423 0133 03
LSV39 S085-M14	8500	1.80	180	M14	28	1.6	96	29.5	16.3	13	3/8"	8423 0133 04
LSV39 S120-5/8	12000	1.80	125	UNC 5/8"	28	1.6	96	29.8	17.6	13	3/8"	8423 0133 07
LSV39 S085-M14 S	8500	1.8	180	M14	19	1.6	96	61.1	16.3	13	3/8"	8423 0133 11

Backing pad not included

Accessories

Model	LSV29	LSV39	See illustration
Backing set, standard type			
Ø 125 mm - 5/8" - soft	4170 0768 80	4170 0768 80	1
Ø 180 mm - 5/8" - soft	4170 0756 80	4170 0756 80	1
Ø 180 mm - 5/8" - stiff	4170 0757 80	4170 0757 80	1
Backing set with cooling ribs			
Ø 125 mm - 5/8" and M14, medium	4150 1962 80	4150 1962 80	2
Ø 180 mm - 5/8" and M14, stiff	-	4150 1962 83	2
Ø 180 mm - 5/8" and M14, medium	4150 1962 81	4150 1962 81	2
Backing set, heavy duty type			
Ø 120 mm - M14	-	4175 0883 93	4
Ø 162 mm - M14	-	4175 0883 91	4
Ø 120 mm - 5/8"	-	4175 0883 92	4
Ø 162 mm - 5/8"	-	4175 0883 90	4
Hand shield for 125-180 mm	-	4150 1936 80	3
Hand shield for 125-180 mm (robust)	-	4150 1941 80	3

Dust extraction, see next page

For included and/or other optional accessories, check ServAid webpage <https://servaid.atlascopco.com/AssertWeb/en-US/AtlasCopco/Catalogue/1>

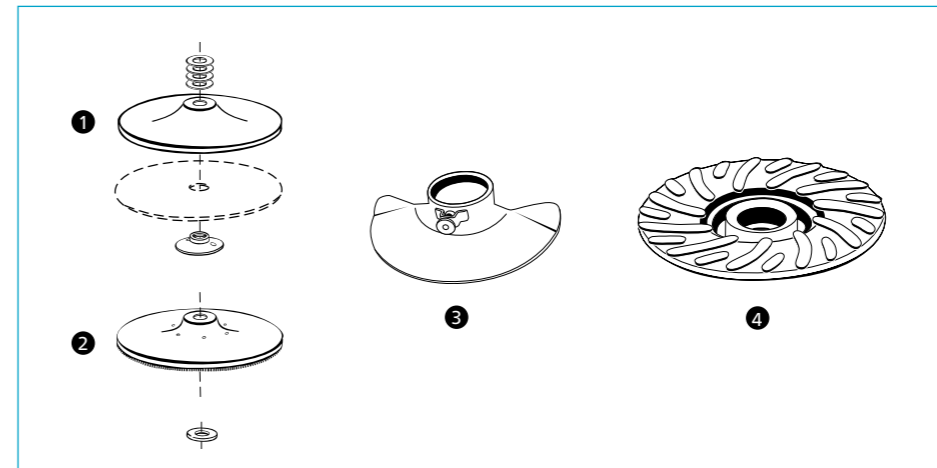

Productivity Kits

Model	Air inlet BSP	Economical air flow	Max hose, 5 m	Coupling	Lubrication	Ordering No.
MIDI-FRL-1/2-BSP EQ10-T13	3/8"	35l/s	Turbo 13	ErgoQic 10	Yes	8202 0850 17

Sanders

dust extraction
for fiber discs, Ø 125-180 mm

	LSV29	LSV39	See illustration
Spot suction kits for sanding with fiber disc. Sanders with UNC 5/8" spindle			
LSV29 S040/S060 5/8", 125 mm, kit	3780 4007 80	-	-
Suction cap 125 mm with brush (incl. in kit)	3780 2650 20	-	1
Backing pad 125 mm (incl. in kit)	3780 2710 30	-	2
Distance washer 12 mm (incl. in kit)	3780 2721 60	-	4
Nut 5/8" (incl. in kit)	3780 2722 00	-	3
LSV29 ST12-13 125 mm - kit	3780 4008 60	-	-
Suction cap 125 mm with brush (incl. in kit)	3780 2650 20	-	1
Backing pad 125 mm (incl. in kit)	3780 2710 30	-	2
Distance washer 9 mm (incl. in kit)	3780 2721 50	-	4
Adapter UNF 3/8" UNC 5/8" (incl. in kit)	4021 0434 00	-	5
Nut 5/8" (incl. in kit)	3780 2722 00	-	3
LSV29 S040/S060 5/8", 180 mm, kit	3780 4007 90	-	-
Suction cap 180 mm with brush (incl. in kit)	3780 2675 00	-	1
Backing pad 180 mm (incl. in kit)	3780 2710 60	-	2
Distance washer 9 mm (incl. in kit)	3780 2721 50	-	4
Nut 5/8" (incl. in kit)	3780 2726 70	-	3
LSV39 180 mm, for 5/8" only - kit	-	3780 4008 84	-
Suction cap 180 mm with brush (incl. in kit)	-	3780 2675 00	1
Backing pad 180 mm (incl. in kit)	-	3780 2710 60	2
Nut 5/8" (incl. in kit)	-	3780 2726 70	3
Distance washer 9 mm (incl. in kit)	-	3780 2721 50	4
Adapter	-	4150 2266 90	-
LSV39 125 mm, for 5/8" only - kit	-	3780 4008 85	-
Suction cap 125 mm with brush (incl. in kit)	-	3780 2650 20	1
Backing pad 125 mm (incl. in kit)	-	3780 2710 30	2
Nut 5/8" (incl. in kit)	-	3780 2726 70	3
Distance washer 9 mm (incl. in kit)	-	3780 2721 50	4
Adapter	-	4150 2266 90	-

	Ordering No.
Vacuum Hose, 1.8 m	
Ø 25 mm for 125 m³/h suction requirement	3780 2724 20
Ø 32 mm for 200 m³/h suction requirement	3780 2724 31
Ø 38 mm for 250 m³/h suction requirement	3780 2724 40
Brush for suction cap	
Separate brush for cap Ø 125 mm (20 mm high)	3780 2678 00
Separate brush for cap Ø 180 mm (30 mm high)	3780 2677 30

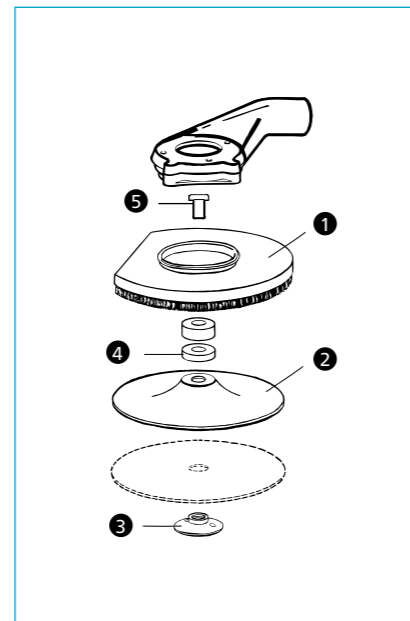

Sanders

for wet sanding



LSV29 S018-5/8

Wet sanding is a cleaner alternative than sanding in certain applications.

LSV29 S018-5/8 wet sanders have a central water supply through the angle head for optimal water distribution on the work surface.

Model	Max free speed r/min	Max output kW	Max pad dia mm	Weight kg	Spindle thread	Spindle length mm	Height over spindle mm	Air consumption at max output l/s	Air consumption at free speed l/s	Rec hose size mm	Air inlet thread BSP	Ordering No.
LSV29 S018-5/8	1800	0.8	180	1.7	5/8-11 UNC	32	104	22	13	13	3/8	8423 0127 52
LSV28 ST008-01-LF	800	0.68	200	2	5/8-11 UNC	32	105	16	5.6	10	3/8	8423 0125 51

For included and/or other optional accessories, check ServAid webpage <https://servaid.atlascopco.com/AssertWeb/en-US/AtlasCopco/Catalogue/1>

Productivity Kits

Model	Air inlet BSP	Economical air flow	Max hose, 5 m	Coupling	Lubrication	Ordering No.
MIDI-FRL-1/2-BSP EQ10-C13	3/8"	23l/s	Cablair 13	ErgoQic 10	Yes	8202 0850 02

Angle sanders

for fiber discs, 50–75 mm



LSV19

These sanders are suitable for applications with high demands on surface finish and requiring tools offering good accessibility.

LSV12/19 sanders are a good choice for this type of finer work. For operator comfort the tools are ergonomically designed with the option of dust extraction. All tools are available with either a collet or a threaded spindle and a speed governor for optimal process speed.



LSV12

Model	Max free speed r/min	Max output kW	Rec pad size dia mm	Collet size mm	Spindle thread	Spindle length mm	Length mm	Weight kg	Height over spindle mm	Air consumption at max output l/s	Air consumption at free speed l/s	Rec hose size mm	Air inlet thread BSP	Ordering No.
With collet														
LSV12 S120-1	12000	0.24	75	6	-	-	166	0.5	76	8.3	3.0	8	1/4"	8423 1124 05
LSV12 S200-1	20000	0.29	50	6	-	-	166	0.5	76	9.5	6.4	8	1/4"	8423 1124 06
LSV19 S080-1	8000	0.37	75	6	-	-	185	0.6	78	11.3	6.5	10	1/4"	8423 0111 46
LSV19 S120-1	12000	0.46	75	6	-	-	185	0.6	78	11.3	7.5	10	1/4"	8423 0111 43
LSV19 S200-1	20000	0.46	50	6	-	-	185	0.6	78	11.3	7.5	10	1/4"	8423 0111 41
LSV19 S200-1F	20000	0.46	50	6	-	-	185	0.6	78	11.3	7.5	10	1/4"	8423 0111 47
With threaded spindle														
LSV12 S120	12000	0.24	75	-	UNC 1/4"	8	166	0.5	58	8.3	3.0	8	1/4"	8423 1124 07
LSV12 S200	20000	0.29	50	-	UNC 1/4"	8	166	0.5	58	8.3	3.0	8	1/4"	8423 1124 08
LSV19 S080	8000	0.37	75	-	UNC 1/4"	8	185	0.6	58	11.3	6.5	10	1/4"	8423 0111 45
LSV19 S120	12000	0.46	75	-	UNC 1/4"	8	185	0.6	58	11.3	7.5	10	1/4"	8423 0111 44
LSV19 S200	20000	0.46	50	-	UNC 1/4"	8	185	0.6	58	11.3	7.5	10	1/4"	8423 0111 42

Backing pad not included

Accessories

Model	LSV12	LSV19	See illustration
Collets			
Collet Ø 1/8"	4150 2226 46	4150 0082 00	-
Collet Ø 1/4"	4150 2226 03	4150 0076 00	-
Collet Ø 3/16"	-	4150 0649 00	-
Collet Ø 5/16"	-	4150 0074 00	-
Collet Ø 3 mm	-	4150 0081 00	-
Collet Ø 5 mm	-	4150 0075 01	-
Collet Ø 6 mm	4150 2226 03	4150 0075 00	-
Collet Ø 8 mm	-	4150 0074 00	-
Collar	4150 2226 02	-	-
Collet nut	4150 2226 04	4150 0760 00	-
Extension 75 mm (3")	-	4150 0674 00	-
Spot suction kit for fibre disc			
Ø 50-75 mm pad (for model with collet)	-	3780 4092 62	1
MultiFlex	8202 1350 20	8202 1350 20	2

For included and/or other optional accessories, check ServAid webpage <https://servaid.atlascopco.com/AssertWeb/en-US/AtlasCopco/Catalogue/1>

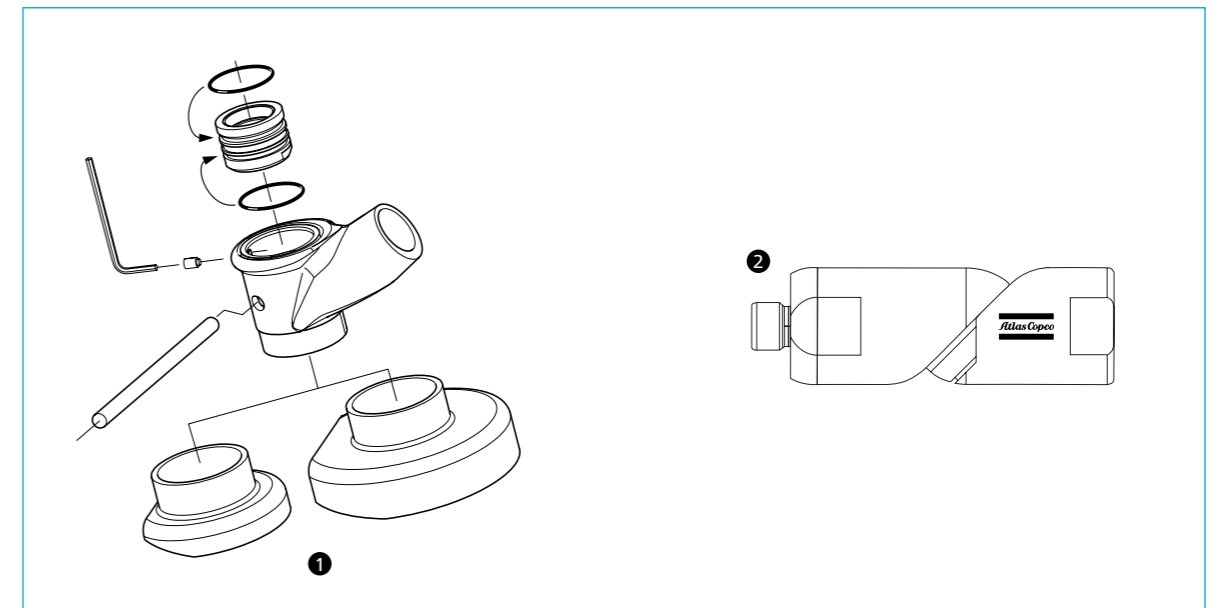

Productivity Kits

Model	Air inlet BSP	Economical air flow	Max hose, 5 m	Coupling	Lubrication	Ordering No.
MIDI-FRL-1/2-BSP EQ08-C10	1/4"	16l/s	Cablair 10	ErgoQic 08	Yes	8202 0850 16

Sanders

orbital and random orbital
for coated abrasives



LST30

LST orbital and random orbital sanders are designed to give you the best surface result in the shortest possible time before painting and coating. They are also suitable for polishing with wax and surface conditioner.

All models are lubrication and silicone free to avoid contamination of the workpiece.

They are available in standard versions, self-suction, or central suction.



LST20



LST21



LST22

Model	Max free speed r/min	Max output W	Max pad size mm	Orbit dia mm	Weight kg	Height over spindle mm	Air consumption at free speed l/s	Rec hose size mm	Air inlet thread BSP	Handle		Ordering No.
										With	Without	
Random orbital - Standard												
LST30 H090-11	9000	300	110	8	1.2	120	7.5	8	1/4"	•	-	8423 0361 64
LST30 H090-15	9000	300	150	8	1.2	120	7.5	8	1/4"	•	-	8423 0361 72
LST30 S090-15	9000	300	150	8	1.1	120	7.5	8	1/4"	-	•	8423 0361 98
Self suction^a												
LST31 H090-15	9000	300	150	8	1.4	120	7.5	8	1/4"	•	-	8423 0363 19
Central suction^b												
LST32 H090-15	9000	300	150	8	1.4	120	7.5	8	1/4"	•	-	8423 0362 55
LST32 S090-15	9000	300	150	8	1.3	120	7.5	8	1/4"	-	•	8423 0362 71
Standard model												
LST20 R350	12000	200	90	5	0.85	95	8	8	1/4"	-	•	8423 0361 65
LST20 R550	12000	200	125	5	0.85	83	8	8	1/4"	-	•	8423 0361 69
LST20 R650	12000	200	150	5	0.85	83	8	8	1/4"	-	•	8423 0361 73
LST20 R525	12000	200	125	2.4	0.85	83	8	8	1/4"	-	•	8423 0361 81
LST20 R625	12000	200	150	2.4	0.85	83	8	8	1/4"	-	•	8423 0361 84
Extraction model - Self suction												
LST21 R550 ^d	12000	200	125	5	0.85	83	8	8	1/4"	-	•	8423 0361 70
LST21 R650 ^d	12000	200	150	5	0.85	83	8	8	1/4"	-	•	8423 0361 74
Extraction model - Central suction												
LST22 R550 ^d	12000	200	125	5	0.85	83	8	8	1/4"	-	•	8423 0361 71
LST22 R650 ^d	12000	200	150	5	0.85	83	8	8	1/4"	-	•	8423 0361 75

^a Includes dust collecting bag.

^b Required air flow 150 m³/h or 88 cfm.

^d 186 mm (7.3") suction hose connector included.

Accessories

LST20/21/22, pad for self stick paper

	Ordering No.	
	Ø 125 mm	Ø 150 mm
For LST20	4112 1233 00	4112 1235 00
For LST21/22	4112 1232 00	4112 1234 00

LST20/21/22, pad for velcro back paper

	Ordering No.		
	Ø 89 mm	Ø 125 mm	Ø 150 mm
For LST 20	4112 1218 00	4112 1216 00	4112 1214 00
For LST 21/22	-	4112 1217 00	4112 1215 00

LST30/31/32

	Ordering No.
Pad velcro, Ø 150 mm	4112 0795 02 ^a
Pad velcro, Ø 110 mm	4112 0792 02 ^b

^aLST30-15 ^bLST30

Dust extraction hose

	Ordering No.
Vacuum Hose, 1.8 m	
Ø 25 mm for 125 m ³ /h suction requirement	3780 2724 20
Ø 32 mm for 200 m ³ /h suction requirement	3780 2724 31
Ø 38 mm for 250 m ³ /h suction requirement	3780 2724 40

For included and/or other optional accessories, check ServAid webpage <https://servaid.atlascopco.com/AssertWeb/en-US/AtlasCopco/Catalogue/1>

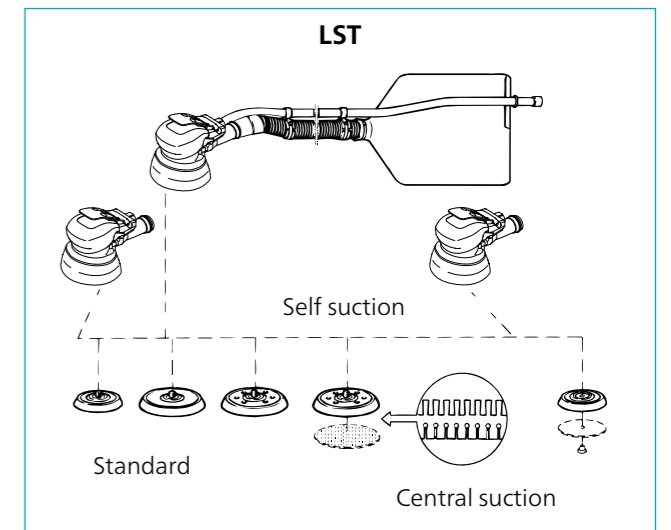

Productivity Kits

Model	Air inlet BSP	Economical air flow	Max hose, 5 m	Coupling	Lubrication	Ordering No.
MIDI-FRL-1/2-BSP EQ08-C10	1/4"	16l/s	Cablair 10	ErgoQic 08	Yes	8202 0850 03

Hole pattern dimensions for sanding paper, dust extraction models

LST20/21/22, 30/31/32

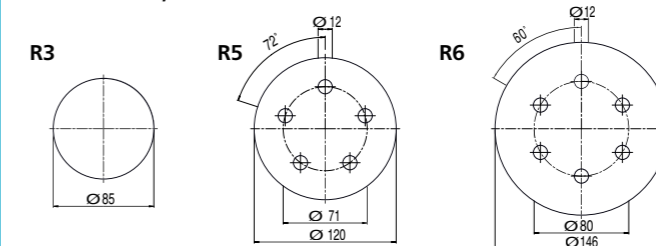

Sanders

belt sanders



LMB27



LMB35

LMB27/LMB35 are suitable for precision sanding where access is difficult with conventional sanders.

The head rotation provides a versatile solution for many applications.

Model	Max output		Belt speed m/min	Belt dimension mm	Weight		Air consumption at free speed		Rec. hose size		Air inlet threadBSP	Ordering No.
	kW	hp			kg	lb	l/s	cfm	mm	in		
LMB27 S014	0.275	0.37	1400	13X305	0.9	2	10	21.2	10	3/8	1/4	8423 0305 10
LMB35 S015	0.350	0.41	1500	19X520	1	2.2	11	23.3	10	3/8	1/4	8423 0305 20

Accessories

CONTACT ARM SANDING BELTS / CONTACT ARM FELT BELTS

Model	Ordering No.
Contact arm sanding belts	
LMB27	
13 x 305 mm (1/2" x 12")(std arm)	4112 3007 88
3 and 6 x 305 mm (1/8" and 1/4" x 12")	4112 3007 78
LMB35	
19 x 520 mm (3/4" x 20-1/2")(std arm)	4112 3008 83
19 x 460 mm (3/4" x 18")	4112 3008 81
Contact arm felt belts	
LMB27	
13 x 305 mm (1/2" x 12")	4112 3007 79

3M SCOTCH-BRITE FELT BELT KIT

	Coars	Medium	Very fine
LMB27			
10 pcs, 13 x 305 mm (1/2"x12")	4170 1210 00	4170 1210 01	4170 1210 02

3M SANDING BELT KIT

	Grit sizw			
	40+	60+	80+	120+
LMB27				
20 pcs, 6 X 305 mm (1/4"x12")	4170 1208 00	4170 1208 02	4170 1208 03	4170 1208 04
20 pcs, 13 X 305 mm (1/2"x12")	4170 1208 05	4170 1208 06	4170 1208 07	4170 1208 08
LMB35				
20 pcs, 19 X 520 mm (3/4"x20-1/2")	4170 1208 13	4170 1208 14	4170 1208 15	4170 1208 16

Service Kits

Model	Ordering No.	Model	Ordering No.
Service kit motor		Service kit belt support	
LMB35	4081 0520 90	LMB35	4081 0521 90
LMB27	4081 0501 90	LMB27	4081 0503 90
Motor casing kit			
LMB35, LMB27	4081 0519 90		

For included and/or other optional accessories, check ServAid webpage <https://servaid.atlascopco.com/AssertWeb/en-US/AtlasCopco/Catalogue/1>

Productivity Kits

Model	Air inlet BSP	Economical air flow	Max hose, 5 m	Coupling	Lubrication	Ordering No.
MIDI-FRL-1/2-BSP EQ08-C10	1/4"	16l/s	Cablaire 10	ErgoQic 08	Yes	8202 0850 03

Polishing



LSV29

Polishing is often used to enhance the look of a surface, remove oxidation and create a protective surface.

We offer LSV29 in various speeds to meet your specific needs.

Model	Max free speed r/min	Max output kW	Max pad dia mm	Spindle thread	Spindle length mm	Weight kg	Air consumption at max output l/s	Air consumption at free speed l/s	Rec hose size mm	Air inlet thread BSP	Ordering No.
LSV29 S040-5/8	4000	0.7	180	5/8-11 UNC	32	1.5	19	6	13	3/8	8423012735
LSV29 S034-5/8	3400	0.8	180	5/8-11 UNC	32	1.7	21	8	13	3/8	8423012744
LSV29 S021-5/8	2100	0.7	180	5/8-11 UNC	32	1.9	19	6	13	3/8	8423012733
LSV29 S021-M14	2100	0.7	180	M14	23	1.9	19	6	13	3/8	8423012734
LSV29 S013-5/8	1300	0.7	180	5/8-11 UNC	32	1.7	25	9	13	3/8	8423012742

Accessories

Backing set for polishing

	Ordering No.
Velcro pads	
150 mm Velcro pad, thread UNC 5/8". Maximum speed 2 500 r/min. To be used together with Velcro sponge heads or Velcro lambswool bonnet.	4112 6092 15
Lambswool bonnet 150 mm with Velcro fitting. Maximum speed 2 500 r/min.	4112 6093 15
150 mm Velcro sponge head, maximum speed 2 500 r/min, White, Dense, firm sponge head for compounding 2-pack paint systems. Excellent result with all leading makes of compound and polish.	4112 6094 15
Threaded pads	
150 mm white sponge head pad, thread UNC 5/8". Maximum speed 4 000 r/min.	4112 6100 15
180 mm soft plastic UNC 5/8" and spanner. Maximum speed 8 000 r/min.	4170 0756 80



For included and/or other optional accessories, check ServAid webpage <https://servaid.atlascopco.com/AssertWeb/en-US/AtlasCopco/Catalogue/1>

Productivity Kits

Model	Air inlet BSP	Economical air flow	Max hose, 5 m	Coupling	Lubrication	Ordering No.
MIDI-FRL-1/2-BSP EQ10-C13	3/8"	23l/s	Cablaire 13	ErgoQic 10	Yes	8202 0850 02

FINE CUTTING



Atlas Copco routers and circular cutters are designed for operator comfort and a first-class result when engraving or fine cutting in composite materials.

Fine cutting

circular cutters



LCS39

Get a top quality result with Atlas Copco circular cutters.

The **LCS39** cuts to a depth up to 26 mm, choose the disc that fit your requirements.

The **LCS39** is equipped with a dust extraction hood, just connect a suction hose.

Model	Max free speed r/min	Max cutter wheel dia mm	Max cutting depth mm	Max output kW	Weight kg	Air consumption at free speed l/s	Rec hose size mm	Air inlet thread BSP	Dust extraction hood	Ordering No.
LCS39 S150D	15000	100	26	1.8	1.8	17.6	13.0	3/8"	•*	8424112507

* Suction requirement: 200 m³/h.

Accessories

Cutter blades

Application	Max thickness of material mm	No. of teeth mm	Ø mm	Hole mm	Ordering No.
Diamond disc for fiber glass	18.0	44/60 (Grain)	75	12	3780 5073 00
Diamond disc for fiber glass	25.0	44/60 (Grain)	100	12	3780 5074 00
Suction hose set (L= 150 mm)	-	-	-	-	3780 2724 31

Productivity Kits

Model	Air inlet BSP	Economical air flow	Max hose, 5 m	Coupling	Lubrication	Ordering No.
MIDI-FRL-1/2-BSP EQ10-T13	3/8"	35l/s	Turbo 13	ErgoQic 10	Yes	8202 0850 17

Dust extraction kits

Model	Ordering No.	Description	Ordering No.
Sanders			
LSV29 S060-5/8	8423 0127 37	Spot suction kit for sanding with fiber disc 125mm (5")	3780 4007 80
LSV19 S200-1F	8423 0111 47	Spot suction kit for fibre disc Ø 50-75 mm pad (for model with collet)	3780 4092 62
LSV19 S080-1	8423 0111 46	Spot suction kit for fibre disc Ø 50-75 mm pad (for model with collet)	3780 4092 62
LSV19 S120-1	8423 0111 43	Spot suction kit for fibre disc Ø 50-75 mm pad (for model with collet)	3780 4092 62
LSV19 S200-1	8423 0111 41	Spot suction kit for fibre disc Ø 50-75 mm pad (for model with collet)	3780 4092 62
LSV29 S060-5/8	8423 0127 37	Spot suction kit for sanding with fiber disc 180mm (7")	3780 4007 90
LSV29 S040-5/8	8423 0127 35	Spot suction kit for sanding with fiber disc 180mm (7")	3780 4007 90
GTG25-S085	8423 2525 03	Spot suction kit for sanding with fibre disc 180mm (7")	3780 4090 27
GTG25-S085-M14	8423 2525 04	Spot suction kit for sanding with fibre disc 180mm (7")	3780 4090 27
GTG25-S085-700	8423 2525 08	Spot suction kit for sanding with fibre disc 180mm (7")	3780 4090 27
LSV39 S066-M14	8423 0133 06	Spot suction kit for sanding with fiber disc 125mm (5")	3780 4008 85
LSV39 S085-M14	8423 0133 04	Spot suction kit for sanding with fiber disc 125mm (5")	3780 4008 85
LSV39 S120-5/8	8423 0133 07	Spot suction kit for sanding with fiber disc 125mm (5")	3780 4008 85
LSV39 S066-5/8	8423 0133 05	Spot suction kit for sanding with fiber disc 125mm (5")	3780 4008 85
LSV39 S085-5/8	8423 0133 03	Spot suction kit for sanding with fiber disc 125mm (5")	3780 4008 85
LSV39 S085-M14 S	8423 0133 11	Spot suction kit for sanding with fiber disc 125mm (5")	3780 4008 85
LSV39 S066-M14	8423 0133 06	Spot suction kit for sanding with fiber disc 180mm (7")	3780 4008 84
LSV39 S085-M14	8423 0133 04	Spot suction kit for sanding with fiber disc 180mm (7")	3780 4008 84
LSV39 S120-5/8	8423 0133 07	Spot suction kit for sanding with fiber disc 180mm (7")	3780 4008 84
LSV39 S066-5/8	8423 0133 05	Spot suction kit for sanding with fiber disc 180mm (7")	3780 4008 84
LSV39 S085-5/8	8423 0133 03	Spot suction kit for sanding with fiber disc 180mm (7")	3780 4008 84
LSV39 S085-M14 S	8423 0133 11	Spot suction kit for sanding with fiber disc 180mm (7")	3780 4008 84
Grinders			
LSV29	8423 0127 47	Spot suction kit for depressed center wheel 125 mm (5")	3780 4008 70
LSV29 ST12-125	8423 0133 07	Spot suction kit for depressed center wheel 125 mm (5")	3780 4008 73
GTG25 F085-180	8423 2525 02	Spot suction kit for depressed center wheel 180 mm (7")	3780 4090 30
GTG25 F085-5/8	8423 2525 13	Spot suction kit for depressed center wheel 180 mm (7")	3780 4090 30
GTG25 F085-M14	8423 2525 11	Spot suction kit for depressed center wheel 180 mm (7")	3780 4090 30
Universal	-	Add on spot suction 125mm (5")	3780 4032 14
Cutting			
LSV48 SA 085	8423 0132 02	Spot suction for diamond cutting wheel 180mm (7")	3780 4093 42
GTG25-F085-18	8423 2525 02	Spot suction for diamond cutting wheel 180mm (7")	3780 4090 35
LSV39 S120-5/8	8423 0133 07	Spot suction kit for Diamond cutting wheel 125mm (5")	3780 4008 74

Spot suction kit for sanding with fibre disc

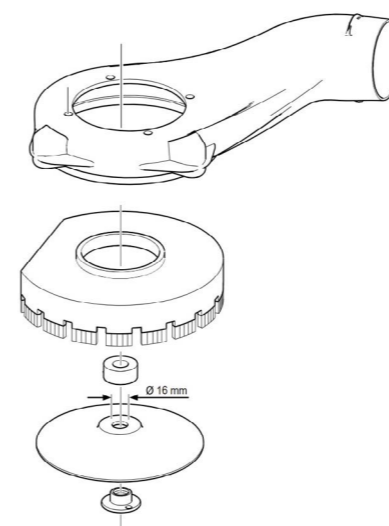

Spot suction kit for depressed center wheel

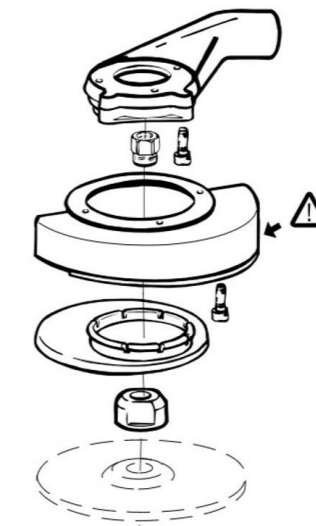

Spot suction for diamond cutting wheels & depressed wheels



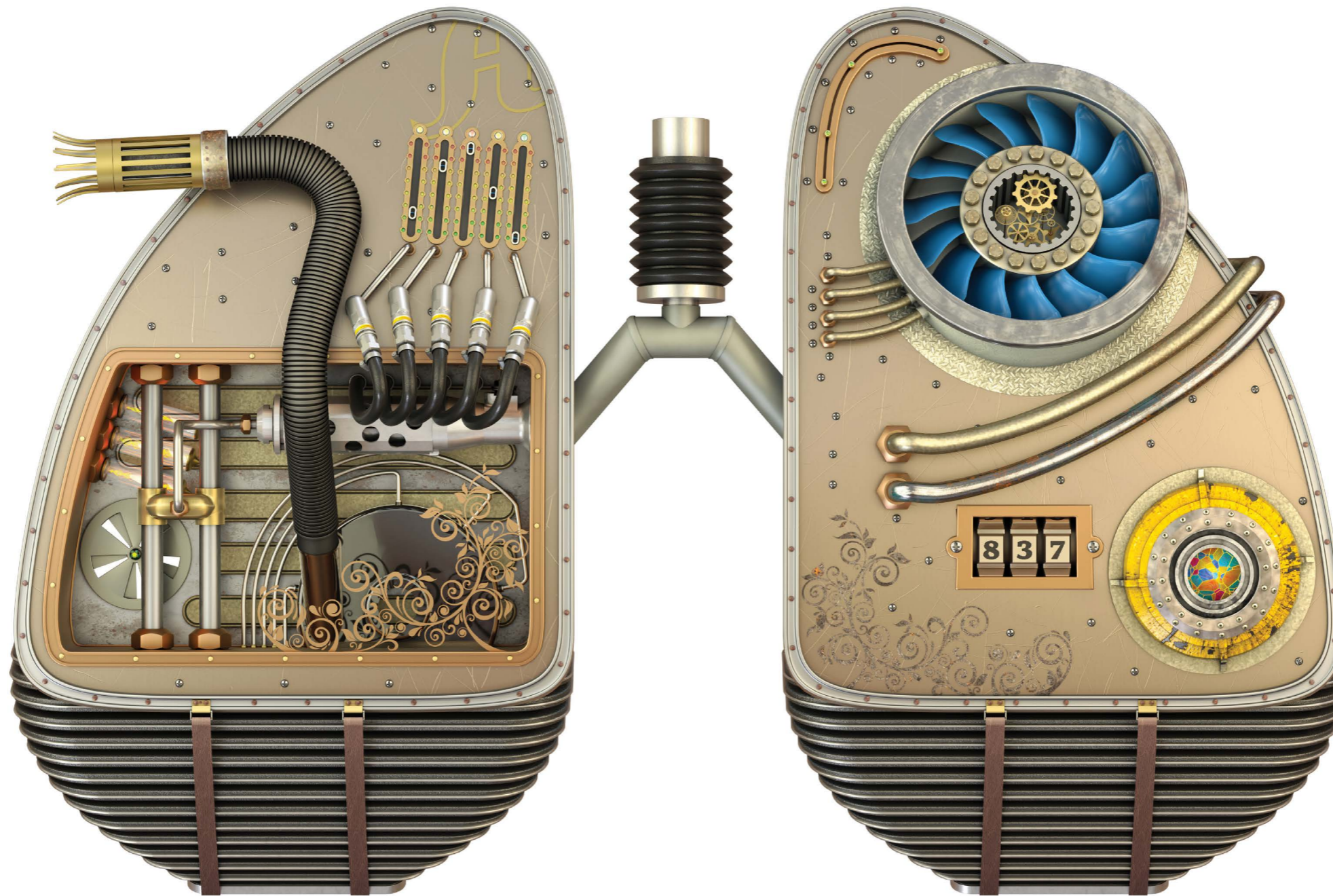

Take a deep breath

Removing material will always produce a fair amount of dust. And many times this dust is not only irritating, but can also be harmful to the operator. Exposure to dust is a major problem - but there are a number of methods to take control of and collect the dust.

The most efficient is dust extraction on the tool, collecting the particles at the very point of creation. A clean and dust-free station means healthy operators and today our tools can be fitted with an efficient dust collector.

It allows your operators to take a deep breath and get the job done.



Scan the code
to learn more
about the initiative

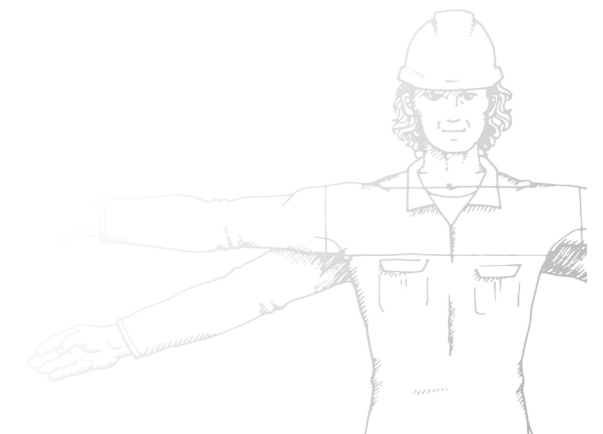

WELD FLUX, PAINT AND RUST REMOVAL



Atlas Copco scalers are ideal for all weld flux, paint and rust removal tasks in foundries, shipyards, weld shops and construction sites. Our range includes vibration damped models, which reduce the operator's exposure to vibrations.

Selection Guide

		Vibration damped	Blowing device	Weld flux removal	Paint & rust removal
Scalers	RVM08	•	•	•	
	RRC13			•	
	RRC13B		•	•	
	RRC13N				•

Scalers



RRC13B

Atlas Copco robust, all-steel scalers are designed to work in the toughest environments.

The tools are ideal for removal of weld flux, paint and rust, and for light concrete trimming. The **RRC13N** needle scaler can handle even the toughest paint and rust removal tasks.

RVM08B and **RRC13B** scalers feature a clean blowing device.

P2506 engraving pen will give a precise result on any hard material, such as aluminum, steel or glass. The needle is easy to change and the tool is small yet durable.



RVM08B



RRC13N



P2506

Model	Blows Hz	Stroke mm	Energy per blow J	Length mm	Weight kg	Air consumption l/s	Rec hose size mm	Air inlet thread BSP	Ordering No.
RVM08B	100	-	-	273	1.7	3.8	6.3	1/4"	8425 0105 40
RRC13	73	35	1.4	221	1.4	4.0	10	3/8"	8425 0101 30
RRC13B	73	35	1.4	231	1.6	4.0	10	3/8"	8425 0101 33
RRC13N	73	35	1.4	352	1.9	4.0	10	3/8"	8425 0101 36

Model	Blow per sec	Length mm	Weight kg	Air consumption l/s	Rec hose size mm	Air inlet thread	Ordering No.
P2506	190	175	0.12	0.6	3.2	1/8"	8425 0102 72

Model	Max free speed, r/min	Length mm	Weight kg	Air cons. l/s	Rec. hose size mm	Air inlet thread BSP	Ordering No.
P2506	225	127	0,14	0,1	5	1/4"	8425 0102 80

Productivity Kits

Model	Air inlet BSP	Economical air flow	Max hose, 5 m	Coupling	Lubrication	Ordering No.
MIDI-FRL-1/2-BSP EQ08-C06-1/8	1/8"	6 l/s	Cablaire 6	ErgoQic 08	Yes	8202 0850 10
MIDI-FRL-1/2-BSP EQ08-C08	1/4"	9 l/s	Cablaire 8	ErgoQic 08	Yes	8202 0850 00
MIDI-FRL-1/2-BSP EQ08-C10	3/8"	16 l/s	Cablaire 10	ErgoQic 08	Yes	8202 0850 07

Accessories

For RRC13, 13B, P2505, P2506

RRC13 / RRC13B	Ordering No.
RRC13 / RRC13B	
Hand guard	3510 0246 90
P2505	
Needle and small parts kit	4081 0068 90
P2506	
P2506 kit*	8425 0102 90
Anvil	3510 0603 00
Chisel Round Nose	3510 0600 00
Chisel Flat 1/4"	3510 0601 00
Chisel Blank	3510 0602 00

* kit includes (Anvil, Chisel Round Nose, Chisel Flat 1/4", Chisel Blank)

For RRC13N Needle-set of 19 needles, length 100 mm

Material	Ordering No.
Steel, standard	3510 0221 90
Steel flat ends	3510 0887 90
Stainless steel flat ends	3510 0228 90
Beryllium copper flat ends (spark resistant)	4081 0068 90

For included and/or other optional accessories, check ServAid webpage <https://servaid.atlascopco.com/AssertWeb/en-US/AtlasCopco/Catalogue/1>

Chisels for RRC13/13B, square shank 13.0 mm

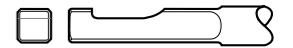

Chisel type	Designation	Width		Length		Square 13 mm (1/2") Ordering No.
		mm	in	mm	in	
	Chisel blank	15	0.59	155	6.1	3085 0020 00
		15	0.59	200	7.9	3085 0020 01
		15	0.59	300	11.8	3085 0020 02
	Flat chisel	15	0.59	165	6.1	3085 0227 00
		15	0.59	200	7.9	3085 0227 01
	Wide flat chisel	35	1.38	165	6.5	3085 0032 00
		35	1.38	200	7.9	3085 0032 01
		35	1.38	300	11.8	3085 0032 02
		55	2.17	165	6.5	3085 0332 00
	Angle scraper chisel	35	1.38	165	6.5	3085 0176 00
		35	1.38	200	7.9	3085 0176 01
		55	2.17	165	6.5	3085 0333 00
	Scaling chisel	15	0.59	155	6.1	3085 0018 00
		15	0.59	200	7.9	3085 0018 02
		15	0.59	300	11.8	3085 0018 01

Chisel type	Designation	Material	Width		Length		Square 13 mm (1/2") Ordering No.
			mm	in	mm	in	
	Flat chisel	Tungsten carbide	10	0.39	120	4.7	3085 0321 00
		Through hardened steel	10	0.39	120	4.7	3085 0325 00
		Tungsten carbide	10	0.39	200	7.9	3085 0321 01
		Tungsten carbide	10	0.39	300	11.8	3085 0321 02
		Tungsten carbide	20	0.79	120	4.7	3085 0345 00
		Through hardened steel	20	0.79	120	4.9	3085 0346 00
	Wide chisel	Tungsten carbide	35	1.38	120	4.7	3085 0322 00
		Through hardened steel	35	1.38	120	4.7	3085 0327 00
		Through hardened steel	35	1.38	300	11.8	3085 0327 01
		Tungsten carbide	35	1.38	300	11.8	3085 0322 01

ROUGH CHISELING



Atlas Copco robust, all-metal chipping hammers are designed to stand up to the roughest handling and cope with the toughest jobs in foundries, shipyards, offshore installations and other heavy industries. Built-in ergonomic features such as vibration dampening help reduce operator fatigue and protect the operator against long-term exposure to vibration.

Selection Guide

		Vibration damped	D-handle design	Extreme blow energy	Heavy duty
Chipping hammers	RRF21-01	•	•		•
	RRF31-01	•	•		•
	RRF41-01	•	•		•
	RRD37-11	•	•		•
	RRD57-11	•	•	•	•
	RRD57-12	•	•	•	•
	RRC22F-01				•
	RRC22F-02				•
	RRC34B-01				•
	RRC65B-01			•	•
RRC75B-01			•	•	

Chipping

hammers



RRD57

Atlas Copco's robust chipping hammers are protected against rough handling by their light metal alloy casings.

RRD and RRF versions are vibration damped for operator comfort. For increased protection a steel cover is available as an optional accessory for the RRF versions. RRC chipping hammers have a sturdy construction that make them highly dependable.



RRF21



RRF41



RRC22F

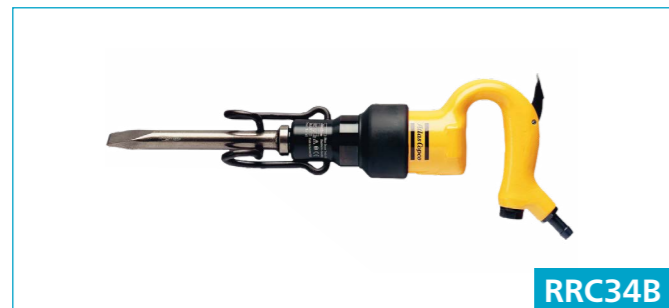

RRC34B



RRC75B

Model	Blows Hz	Stroke mm	Energy per blow J	Length mm	Weight kg	Bush-ing mm	Air consumption l/s	Rec hose size mm	Air inlet thread BSP	Bushing type		Inte-grated hose barb	Vibra-tion damped	Ordering No.
										Hex	Round			
RRF21-01	57	33	2.0	245	1.75	12.7	6.5	10.0	3/8"	•	-	-	•	8425 1104 05
RRF31-01	38	43	4.4	265	2.5	12.7	7.5	10.0	3/8"	•	-	-	•	8425 1104 15
RRF31-02	38	43	4.4	265	2.5	12.7	7.5	10.0	3/8"	-	•	-	•	8425 1104 16
RRD37-11	35	70	6.8	418	3.0	17.3	7.2	12.5	-	•*	-	•	•	8425 1101 22
RRD57-11	31	92	9.3	458	3.4	17.3	9.5	12.5	-	•*	-	•	•	8425 1103 20
RRF41-01	44	50	-	447	6.3	19	10	12.5	1/2"	•	-	-	•	8425 1104 41
RRD57-12	31	92	9.3	458	3.4	17.3	9.5	12.5	-	-	•	•	•	8425 1103 38
RRC22F-01	62	52	2.7	260	2.2	12.7	6.2	10.0	3/8"	•	-	-	-	8425 0202 22
RRC22F-02	62	52	2.7	260	2.2	12.7	6.2	10.0	3/8"	-	•	-	-	8425 0202 30
RRC34B-01	45	67	5.5	330	4.5	17.3	8.0	12.5	-	•	-	•	-	8425 0212 53
RRC65B-01	40	50	10.0	335	5.9	17.3	10.8	12.5	-	•	-	•	-	8425 0225 33
RRC75B-01	30	75	16.0	390	6.5	17.3	14.0	12.5	-	•	-	•	-	8425 0225 58

* Spline

Accessories

Model	Ordering No.
Power regulator	
RRF21 and -31	3512 0273 80
Retainer, open type	
RRF21	3512 0290 90
RRF31	3512 0305 90
Retainer closed type	
RRF 21	3512 0289 90
RRF 31	3512 0304 90

For included and/or other optional accessories, check ServAid webpage <https://servaid.atlascopco.com/AssertWeb/en-US/AtlasCopco/Catalogue/1>

Retainer, open type

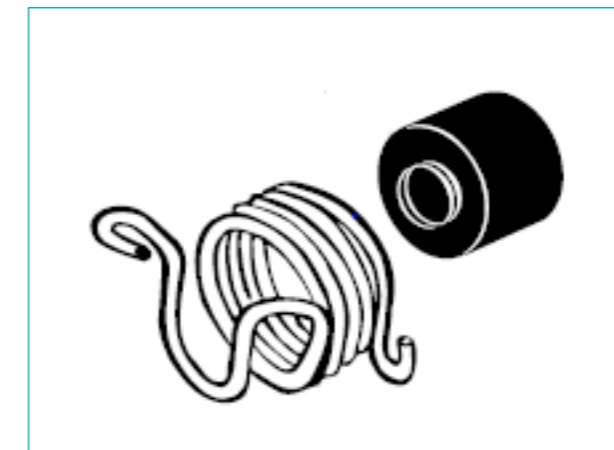

Productivity Kits

Model	Air inlet BSP	Economical air flow	Max hose, 5 m	Coupling	Lubrication	Ordering No.
MIDI-FRL-1/2-BSP EQ08-C10	3/8"	16l/s	Cablair 10	ErgoQic 08	Yes	8202 0850 07
MIDI-FRL-1/2-BSP EQ10-R13-W	-	16l/s	Rubair 13	ErgoQic 10	Yes	8202 0850 15

Chisels



Chisels for Chipping hammers. All chisels are normally through hardened. Otherwise, see tables.

Figure	Shank type	Tools	Table
	Hexagon and round shank ISO, round collar 12.7 mm	RRC22F-01, RRC22F-02, RRF21, RRF31	1
	Hexagon shank ISO without round collar 17.3 mm	RRC34-01, RRC65-01, RRC75-01	2
	Round shank ISO, without collar 17.3 mm	RRC34-02, RRC65-02, RRC75-02	2
	Hexagon shank ISO round collar 17.3 mm	RRC34B-01, RRC65B-01, RRC75B-01	3
	Round shank USI, with splines 17.3 mm	RRD37, RRD57	3
	Hexagon shank, round collar 19x50 mm	RRF41-01	4

Table 1
A. Chisels with hexagon shank 12.7 mm
B. Chisels with round shank 12.7 mm







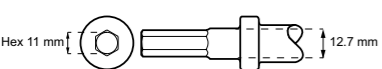
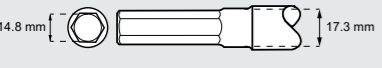
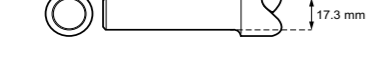
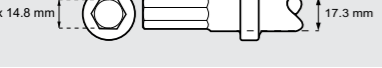
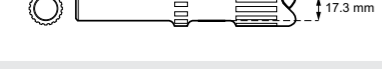

Chisel type	Designation	Width		Length		A	B
		mm	in	mm	in	Hexagon ISO 12.7 mm (1/2") Ordering No.	Round ISO 12.7 mm (1/2") Ordering No.
	Chisel blank	13	0.51	200	7.9	3085 0182 00	
		13	0.51	350	13.8	3085 0182 01	
		13	0.51	400	15.7	3085 0182 04	
		13	0.51	500	19.7	3085 0182 05	
	Flat chisel	13	0.51	200	7.9	3085 0183 00	3085 0184 00
		15	0.59	200	7.9	3085 0376 00	
	Sharp chisel	15	0.59	200	7.9	3085 0170 00	
		15	0.59	300	11.8	3085 0170 01	
	Spot weld chisel	17	0.96	200	7.9	3085 0301 00	
	Angle scraper chisel	30	1.18	200	7.9	3085 0262 00	
	Pipe cutting chisel	20	0.78	200	7.9	3085 0302 00	
		35	1.38	200	7.9	3085 0303 00	
	Plate cutting chisel	14.5	0.57	200	7.9	3085 0263 00	
	Plate cutting chisel	16	0.62	200	7.9	3085 0173 00	
	Moil point chisel	13	0.51	200	7.9	3085 0297 00	
		13	0.51	305	12.0	3085 0297 01	

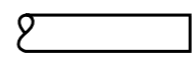
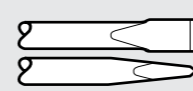
Table 3
A. Chisels with hexagon shank 17.3 mm
B. Chisels with round shank, with splines 17.3 mm

Chisel type	Designation	Width		Length		A	B
		mm	in	mm	in	Hexagon 17.3 mm (6.8") ISO Ordering No.	Round 17.3 mm (6.8") ISO Ordering No.
	Chisel blank	23	0.91	200	7.9	3085 015 00	
		23	0.91	560	22.00		3085 0140 01
	Flat chisel	23	0.91	225	8.9	3085 0225 00	3085 0224 00

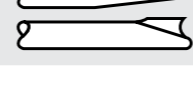

Atlas Copco AB
(publ) SE-105 23 Stockholm, Sweden
Phone: +46 8 743 80 00
Reg. no: 556014-2720
atlascopco.com

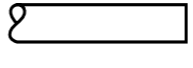
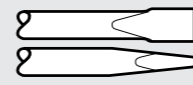